

# OEM Bluetooth-Serial Module, Parani™ ESD110V2

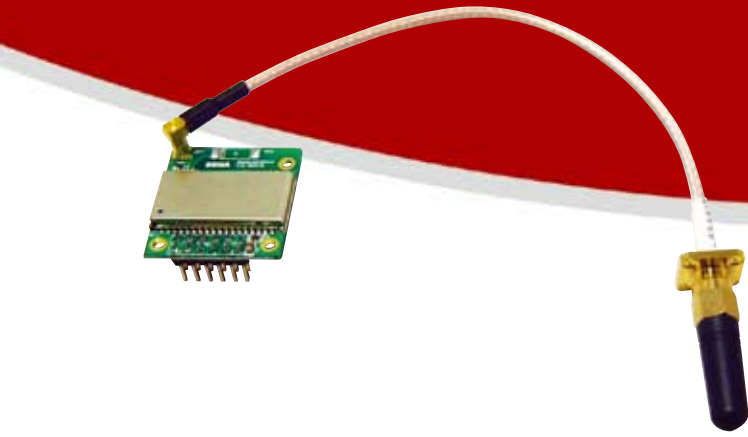

## Features

- Output Interface UART, Bluetooth Specification v2.0+EDR
- Transmit Power - Max. 18dBm
- Receiving Sensitivity: -90dBm(0.1%BER)
- Compact size - 27.5 x 30.0 x 14.0 (mm)  
1.08 x 1.18 x 0.55 (in)
- Provides transparent RS232 serial cable replacement.
- Supports up to 4 multiple simultaneous connections.
- Profile: Bluetooth Serial Port Profile.
- Interoperability with PDA, laptops etc.
- Firmware upgrade via windows-based software (ParaniUpdater)
- Working distance ( In an open field ):  
Nom. 100 meters, up to 1000m using patch antenna
- Easy to use Windows configuration tool available.
- No external drivers required.

The **Parani-ESD110V2** is a Bluetooth v2.0+EDR Class1 type Embedded Bluetooth serial module for RS232 cable replacement. The Parani-ESD110V2 is a compact size Bluetooth serial module. By default, it supports 100 meters of wireless transmit distance. The Parani-ESD110V2 has an extension option so that users can extend the transmit distance up to 1,000 meters using optional antennas. The Parani-ESD110V2 also supports up to 4 multiple simultaneous connections.

Typical application areas of the Parani-ESD110V2 include:

- RS232 cable replacement
- Wireless Factory monitoring
- Truck/Bus monitoring system
- PLC programming
- Car Diagnostics
- Wireless Printing
- Wireless POS system
- Wireless logistics
- Wireless machine(healthcare/industrial) monitoring

## Pin Assignment

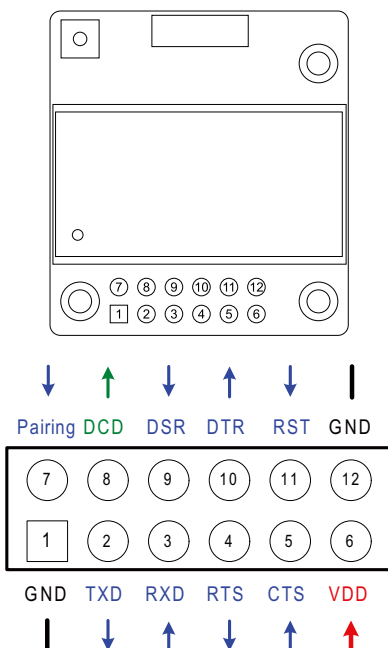

Pin #	Signal	Direction	Description	Signal Level
1	GND	-	Power Ground	Ground
2	TxD	Output	UART Data Output	TTL
3	RxD	Input	UART Data Input	TTL
4	RTS	Output	UART Ready to Send	TTL
5	CTS	Input	UART Clear to Send	TTL
6	VDD	Input	DC Input (3.0~3.3V)	Power
7	Pairing	Input	Pairing Input (Active Low)	TTL
8	DCD	Output	Bluetooth Connect Detect (Active Low)	TTL
9	DSR	Input	Data Set Ready	TTL
10	DTR	Output	Data Terminal Ready	TTL
11	RST	Input	Reset (Active Low)	TTL
12	GND	-	Power Ground	Ground

## Specifications

### Serial Interface

- UART interface, 2.54mm Pin Header 2X6 (12pin)
- Serial UART speed up to 921.6kbps
- CTS/RTS flow control, DTR/DSR for loop-back & full transfer

### Bluetooth

- Bluetooth v2.0 + EDR Class1
- Level - 18 dBm
- Profile: Serial Port Profile
- Working distance:
  - Stub Antenna (+1dBi) - Stub Antenna (+1dBi) - 100 meters
  - Stub Antenna (+1dBi) - Dipole Antenna (+3dBi) - 150 meters
  - Dipole Antenna (+3dBi) - Dipole Antenna (+3dBi) - 200 meters
  - Dipole Antenna (+3dBi) - Dipole Antenna (+5dBi) - 300 meters
  - Dipole Antenna (+3dBi) - Patch Antenna (+9dBi) - 500 meters
  - Dipole Antenna (+5dBi) - Dipole Antenna (+5dBi) - 400 meters
  - Dipole Antenna (+5dBi) - Patch Antenna (+9dBi) - 600 meters
  - Patch Antenna (+9dBi) - Patch Antenna (+9dBi) - 1000 meters

**Max. Tx power:** 18 dBm

**Receive Sensitivity:** -90 dBm

**Configuration:** ParaniWIN, ParaniWizard, Modem AT command set

**Firmware upgrade:** by ParaniUpdater

### Power

- Supply voltage: 3.3V DC
- Supply current: 10mA - 60mA

### Environmental

- Operating temperature: -30°C to 80°C
- Storage temperature: -40°C to 85°C
- Humidity: 90% Non-condensing

### Physical properties

- Dimension:
  - 27.5 mm L (1.08 in )
  - 30.0 mm W (1.18 in )
  - 14.0 mm H (0.55 in )
- Weight: 6g

**Regulatory Approvals:** FCC, CE, TELEC, KCC, SIG

**SIG QDID:** B015896

**Warranty:** 1-year Limited Warranty

## Parani-ESD110V2 Starter Kit

Parani-ESD110V2 Starter Kit includes the development board with the sample circuitry for Parani-ESD110V2 interface, power, RS232 Interface, Reset, LEDs, Pairing, H/W flow control for user device development.

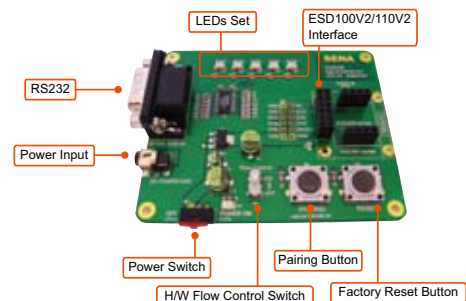

## Ordering Information

Part number	Description/Package Contents
<b>ESD110V2-00</b>	Parani-ESD110V2 OEM Bluetooth-Serial Module-Class 1 Bluetooth v2.0+EDR with antenna extension option (module only - antenna and cable NOT included)  <b>Package contents:</b> - Parani-ESD110V2 Module Only (antenna and cable NOT included)
<b>ESD110V2-01</b>	Parani-ESD110V2 OEM Bluetooth-Serial Module-Class 1 Bluetooth v2.0+EDR with antenna extension option (antenna and cable included)  <b>Package contents:</b> - Parani-ESD110V2 Module - Stub Antenna (SAT-G01R) - Antenna extension cable (EEC-G01R)
<b>ESD110V2SK-01</b>	Starter Kit for Parani-ESD110V2, ESD110V2 included.  <b>Package contents:</b> - Parani-ESD110V2 Module - Development board - Serial data cable - DC Power Adapter - A hardcopy of Quick Start Guide

### Optional Accessories

Part number	Description
<b>SAT-G01</b>	1 dBi Stub Antenna - SMA Male-Left-Hand Thread
<b>SAT-G01R</b>	1 dBi Stub Antenna - RP-SMA Plug Right-hand Thread
<b>DAT-G01</b>	3 dBi Dipole Antenna - SMA Male-Left-Hand Thread
<b>DAT-G01R</b>	3 dBi Dipole Antenna - RP-SMA Plug Right-hand Thread
<b>DAT5-G01R</b>	5 dBi Dipole Antenna - RP-SMA Plug Right-hand Thread
<b>PAT-G01</b>	9 dBi Patch Antenna with SMA Male-Left-Hand Thread Default Cable
<b>PAT-G01R</b>	9 dBi Patch Antenna with RP-SMA Plug Right hand Thread Default Cable
<b>RFC-G01</b>	1m Antenna Extension Cable for Patch Antenna PAT-G01
<b>RFC-G01R</b>	1m Antenna Extension Cable for Patch Antenna PAT-G01R
<b>EEC-G01</b>	15cm SMA Left-Hand Thread Antenna Extension Cable for ESD110V2/210
<b>EEC-G01R</b>	15cm RP-SMA Right-Hand Thread Antenna Extension Cable for ESD110V2/210

For more information,  
 please visit us at <http://www.sena.com>

### U.S. / Canada / South America

Tel: 408-448-1997 Fax: 408-907-3738  
 Sales and Support Toll Free (US/Canada): 8669-US-SENA (866-987-7362)  
 General Information Toll Free (US/Canada): 8668-US-SENA (866-887-7362)

### EU / Africa

Tel: +33 (0)1 53 53 16 29 Fax: +33 (0)1 70 24 70 90

### Asia / Pacific

Tel: +82-2-576-7362 Fax: +82-2-573-7710

### Contact us via E-mail

General Information: [info@sena.com](mailto:info@sena.com)  
 Sales & Distribution: [sales@sena.com](mailto:sales@sena.com)  
 Technical Support: [support@sena.com](mailto:support@sena.com)