



User's Manual

Version 1.0.1

English



1620 Oakland Road Suite D206 San Jose, CA 95131 United States
 Toll Free (US/Canada): 8668-US-SENA (866-867-7362)
 Tel: +1 (408) 573-7425 Sales direct tel: +1 (408) 922-9786
 Fax: +1 (408) 907-3738
 www.sena.com / sales@sena.com

1. Introduction

The LTC100 is a high performance signal converter between RS-232 and RS-422/485 which operates with or without external power source. It supports both half duplex 2-wire RS-485 and full duplex 4-wire RS-422. The LTC100 is also equipped with 15 KV ESD surge protector to protect itself against damage from electrostatic discharge. The LTC100 is covered by 1-year limited Sena Warranty from the date of your purchase.

2. Features

- The LTC100 is a serial communication interface converter which converts RS232 signals to RS422 or RS485 signals and extends the distance up to maximum 1,2Km. It also allows to be connected to maximum 32 devices by Multi-drop mode as well as Point to Point mode.
- The LTC100 is designed to be operated without any external power supply, when it is connected to PC or to RS232 connector of various system. But a connector for the external power (not included in the product package) is also equipped for the case that an external power supply should be used.
- The LTC100 includes highly-effective Surge Protector to protect itself from the transient voltage(Max. 15,000 volt) coming along the communication line.
- The LTC100 has a fast automatic TX enable circuit for RS485, which makes it a perfect solution for any installing environment without any additional software work.

3. Specifications

Model	LTC100 : DB9 Connector, Automatic opening-closing function, terminal resistor
Communication type	Asynchronous serial communication
Transmission speed	Maximum 115,2Kbps
Distance	Maximum 1,2Km
Connector	RS232 side : DB9 Female RS422/RS485 side : Terminal Block
Slide switch	RS422/RS485 : RS422/RS485 selection
Power	Power off : RS232 DTR, TXD, RTS signal Power on : External power adapter <DC 7V - 12V, IN(-)/Out(+)>
Weight	33g
Internal connection	DCD, DSR, CTS pins are selectively connected to GND
Terminal resistor	RS422/RS485 common jumper : JP2 jumper connects or disconnects terminal resistor.
Circuit protection	15,000 volt-surge protector included,
LEDs	TXD, RXD, PWR
Mode	RS422 mode : Point-to-Point, Multi-Drop RS485 mode : Echo, Non-Echo
RTS Control	Auto Toggling
Environment	Operating Temperature : 0 ~ 55°C (32~131°F) Storage Temperature : -20~70°C (-4~158°F) Humidity : 5 ~ 95% Non-Condensing
Regulatory approvals	CE, FCC, KCC
Warranty	1-year Limited Warranty

4. Dimension

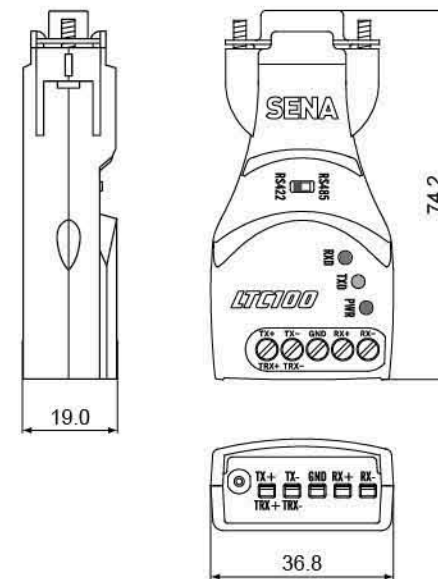

5. Connectors

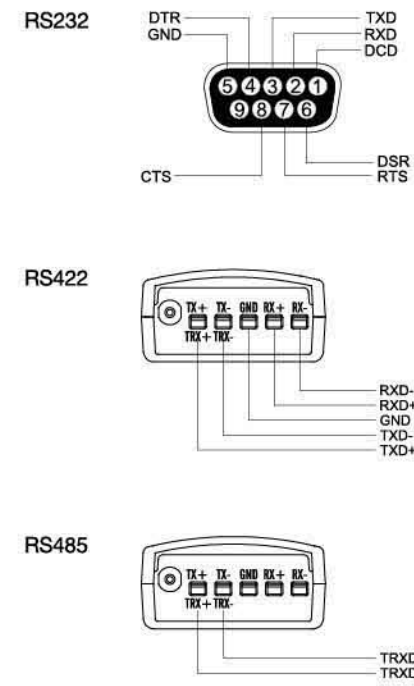

6. Power Supply

The LTC100 can be port-powered from the RS232 port when no external power source is connected to the unit. When it is port-powered, either TXD, RTS or DTR signal should stay ON to supply the power to the LTC100 properly. If the application doesn't allow any of those signals to stay ON, optional external power adaptor or other external power source should be used to power the LTC100. You can recognize whether the power is properly supplied or not by checking the power LED on the LTC100. The power circuit of the LTC100 includes a high-capacity capacitor to provide stable power to the unit when it is port-powered. Therefore there can be a time delay (within 0.1 sec) until this capacitor is filled with enough power and to work correctly. If the application program controls TXD, RTS and DTR signals directly, it is recommended to wait about a second initially before start to use the LTC100. If the power LED doesn't turn on by using the port-power, please use external power source to power the unit.

7. Terminal Resistor

When a communication error occurs due to noise on the lines, install the terminal resistors to solve the problem.

- Terminal resistor installation
 - Open the case, connect the jumper inside and then install the terminal resistors.
 - Refer to '8. Installation' for more detail.

8. Installation

The LTC100 is designed to meet various installation environments by selecting operation mode. Please set the slide switch on the top of the unit according to your application.

- The RS422/RS485 slide switch selects the signal interface type
 - If set to RS422, it converts RS232 to RS422
 - If set to RS485, it converts RS232 to RS485

Once the slide switch is set, connect RS422 (4 lines) or RS485 (2 lines) cables to the terminal block of the unit and tighten the screws with a screw driver. Then connect the DB9 connector side to PC or RS232 port of the equipment. It may not be necessary to connect the GND pin depending on the installation.

Leading M2M Solutions

SENA Technologies

■ Setting Terminal Resistor-JP2, RT

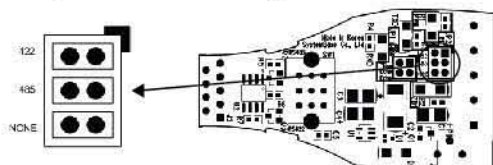

- 422 : Install RS422 Terminal Resistor,
- 485 : Install RS485 Terminal Resistor,
- NONE : Not Install any Terminal Resistor,

■ Setting RS485 Comm. Mode-JP1, 485_MODE

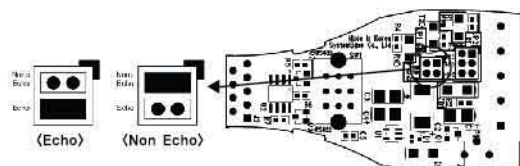

- Echo** : Select RS485 Echo mode, Data from TXD of RS232 port are transmitted to the other device through TRX+/TRX- of RS485 port, and go back to RXD of RS232 port at the same time, So the data transmitted can be checked in the TX side,
- Non Echo** : Select RS485 Non Echo mode, Data are transmitted to the other device only.

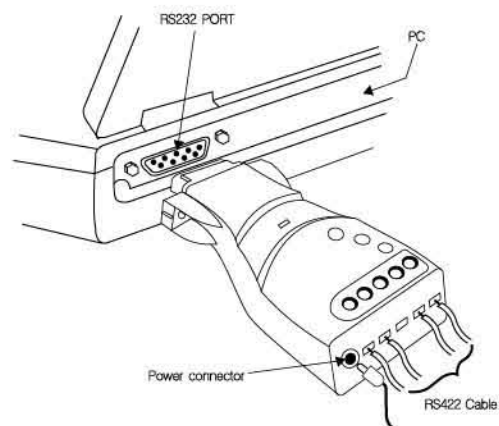

< RS422-interface installation example >

9. The wire connection for RS422

This wire connection is used when trying 1:1(Point to Point) and 1:N(Multi-Drop) full-duplex communication(Max,10 units)

■ Slide Switch of Host & Terminal side



- * As the RS422 interface type, LTC100 automatically supports both Point to Point mode and Multi-Drop mode,
- * In RS422 Multi-Drop mode, the LTC100 of host side need not open or close the output signal line because it may always transfer communication data to terminal side; however, that of terminal side must open or close the output signal line when it sends or receives communication data, But in this product, all operation is controlled by hardware circuit, therefore no operation is required by application program,

■ The wire connection of LTC100

(Point to Point)

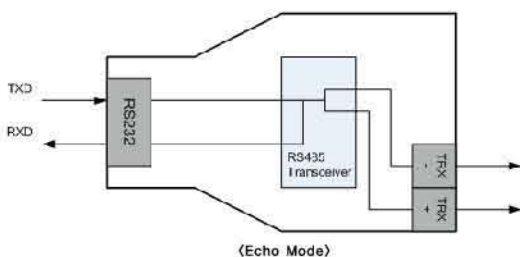
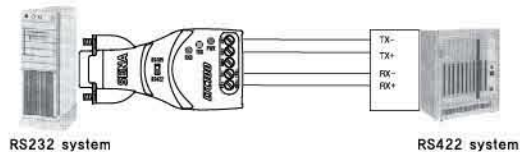

(Echo Mode)

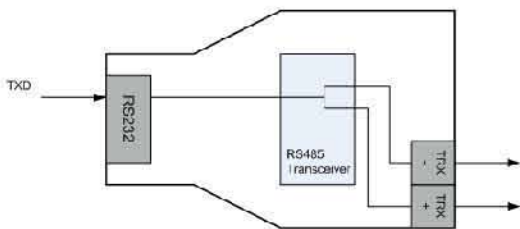

(Non Echo Mode)

(Multi-Drop)

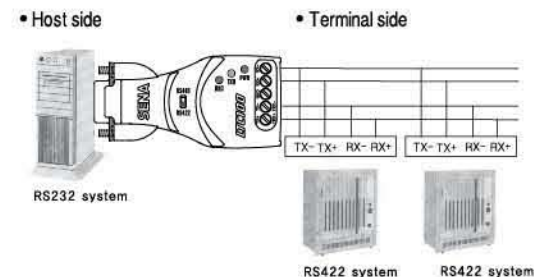

- * DCD, DSR, CTS pins are selectively connected to GND inside of converter,
- * Check and confirm if the power LED is turned on during the operation,

10. The wire connection for RS485

This wire connection is used when trying N:N half-duplex communication (Max, 32 units)

■ Slide Switch of Terminal side



- * Basically, as the RS485 interface type, both the host

side and the terminal side are regarded as just terminals, it is required to enable/disable transmitter to send or receive data, The LTC100 enables/disables transmitter using hardware circuit so no additional software work is required,

- * In case of RS485 setting, both Echo and Non-Echo mode are Supported,

■ The wire connection of LTC100

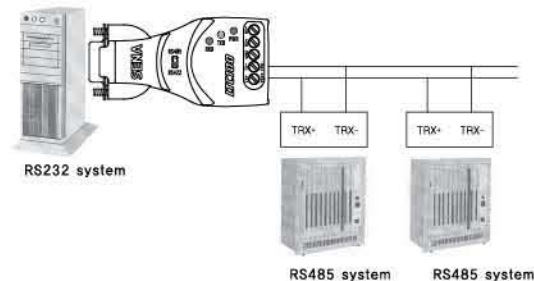

- * DCD, DSR, CTS pins are selectively connected to GND inside of converter,
- * Check and confirm if the power LED is turned on during the operation,

(Memo)

(Memo)

Note: This equipment has been tested and found to comply with the limit for a Class A digital device, pursuant to part 15 of the FCC Rules. These limits are designed to provide reasonable protection against harmful interference when the equipment is operated in a commercial environmental. This equipment generates, uses, and can radiate radio frequency energy and, if not installed and used in accordance with the instruction manual, may cause harmful interference to radio communications. Operation of this equipment in a residential area is likely to cause harmful interference in which case the user will be required to correct the interference at his own expense.